

An Improved Cell Volume Analyzer*

J. T. MERRILL,† N. VEIZADES,† H. R. HULETT,† P. L. WOLF,‡ AND L. A. HERZENBERG†

Departments of Genetics and Pathology, Stanford University School of Medicine, Stanford, California 94305

(Received 21 September 1970; and in final form, 15 March 1971)

A cell volume sensing instrument has been built which employs the principle used in the Coulter counter in which a cell changes the impedance of a narrow orifice as it passes through the orifice. An improved transducer utilizes a coaxial flow of the cell suspension inside a sheath of cell-free solution through the orifice, thereby avoiding some drawbacks of earlier systems. The instrument is described, and the procedure necessary to achieve acceptable operation is discussed. The output for normal human red blood cells is nearly symmetrical with a narrow peak. Abnormal blood samples show various departures from symmetry and narrowness of peak. The output of this instrument is compared with that from a commercially available instrument, and our data show a more accurate representation of the actual distribution of blood volumes. The resolution of this instrument is such that it could be of significant value in a clinical laboratory.

INTRODUCTION

WE have built an instrument which senses the volume of individual biological cells and plots a distribution of numbers of cells as a function of volume. The design is based on the original Coulter instrument but has significant improvements in the transducer. As in the Coulter counter,¹ two electrically insulated chambers filled with a conductive solution are connected by a very narrow orifice through which a cell suspension passes. A current source establishes an electrical potential across the orifice so that as a cell passes through the orifice, it causes a pulse change in the impedance of the circuit. The amplitude of this pulse is a function of the volume of the cell. Over 100 000 cells/min can be passed through the orifice sequentially to produce a volume distribution of the suspension.

The transducer has been improved by injecting the cell suspension so that it flows along the axis of the transducer orifice, surrounded by an outer cell-free solution, similar to the systems of Crosland-Taylor,² Mullaney *et al.*,³ and Thom *et al.*⁴ The inner and outer streams are the same buffered saline solution, except that the inner stream contains one part whole blood to 4000 parts diluent. With proper adjustment of pressures and rates of flow, the two flows remain coaxial as they pass through the orifice, thereby subjecting each cell to essentially the same field in the center of the orifice. This central flow results in a more accurate determination of cell volumes since edge effects of the orifice are avoided.

Leif⁵ has published an excellent critical survey of many papers dealing with this sort of impedance sensing, showing that some modification of the standard Coulter orifice is required to give more artifact-free distributions. Lushbaugh and co-workers have produced volume distributions of cells⁶⁻⁹ and have obtained bimodal distributions for human red blood cells.^{8,9} This finding has since been shown to be an artifact of high current density by Kubitschek¹⁰ and Van Dilla *et al.*¹¹⁻¹³ Van Dilla, using a Coulter orifice, showed that red blood cells possess a unimodal distribution slightly skewed to larger volumes. Data

furnished by Bull¹⁴ and Bahr and Zeitler¹⁵ indicate that the true volume distribution of red blood cells (erythrocytes) is close to being symmetrical and nearly Gaussian, unlike the more skewed curves of other authors. Thom *et al.*⁴ investigated the electrical characteristics of the Coulter orifice and, using a coaxial flow system, demonstrated an increased resolution in sizing red blood cells. The studies of Bull¹⁴ and Thom *et al.*⁴ have indicated several ways in which existing volume sensing instruments could be improved. We have incorporated such improvements into this system, and the output conforms well to a narrow, nearly symmetrical Gaussian distribution for normal erythrocytes. Atypical samples of blood have been analyzed and their volume distributions show significant differences from normal. This impedance analyzer could have many clinical and research applications where the parameters of interest are related to the different volumes of various cell populations.

DESCRIPTION OF THE INSTRUMENT

The construction of the apparatus is shown in Figs. 1 and 2. Two reservoirs, one containing the cell suspension, the other containing the outer flow solution, are pressurized

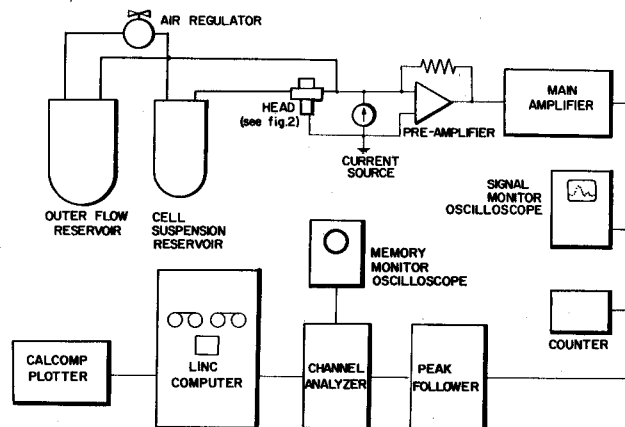

FIG. 1. Block diagram of the volume analyzer.

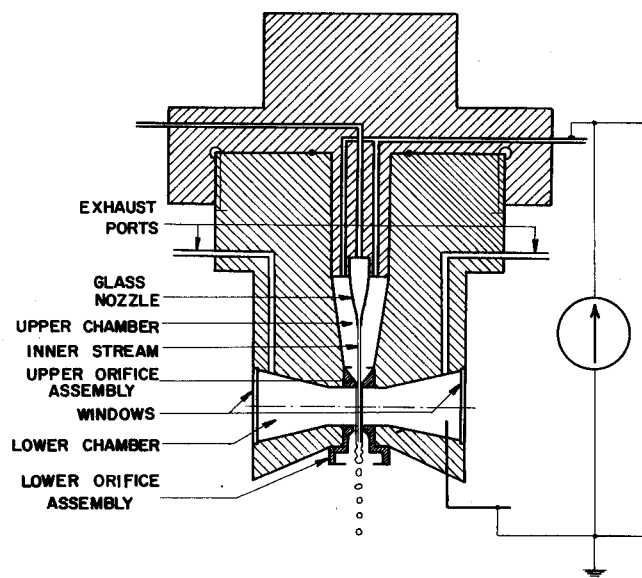

FIG. 2. Diagram of the head.

to about $0.7 \text{ kg} \cdot \text{cm}^{-2}$. Fine adjustment of the pressures, so as to insure coaxial flow and the desired cell flow rate, is accomplished by raising or lowering the reservoirs with respect to each other. As little as 1.3 cm of additional head pressure greatly affects the cell flow rate. The pressure forces the two fluids through polyethylene tubing, the cell suspension also through a 400-mesh stainless steel filter (average pore size 30μ) and into the head (see Fig. 2).

The Lucite head is divided into an upper chamber and a lower chamber which are connected by the upper orifice assembly in which the cells are measured. The lower orifice assembly keeps the lower chamber fluid filled and relatively bubble free. Both orifice assemblies consist of a Kel-F plastic holder and a ruby jewel 1.2 mm in diameter and 0.25 mm thick with a hole in its center 50μ in diameter and 100μ long. This jewel is commercially available from jewelers or watch repair shops. The lower chamber has four quartz windows which allow the experimenter to check for dirt or bubbles which would give false data. These windows also permit examination of the optical properties of the cells, if desired. Exhaust ducts connected to each window allow the system to be flushed with the outer flow solution if problems develop. The two orifice assemblies can be removed for cleaning.

The outer flow solution enters the upper chamber through two channels on opposite sides of the central glass nozzle. The glass nozzle, with a tip inside diameter of about 125μ , injects the cell suspension into the center of the stream. The double stream remains coaxial as it passes through the upper orifice, where the Reynolds number is about 500, crosses the lower chamber, and exhausts through the lower orifice. The flow rate for the

outer stream is approximately 0.025 ml/sec and the rate for the inner stream is about a tenth as much.

Electrical contact to the upper chamber is made at the stainless steel tube through which the outer flow solution enters the head. The lower chamber is grounded by a platinum electrode which makes contact with the solution. A dc source is applied to the circuit using a high voltage supply and a high series resistance to provide essentially constant current so that a signal, proportional to the change in resistance, is generated as cells pass through the upper orifice. The signal is dc amplified and fed into a Nuclear Data amplifier-peak follower,¹⁶ which samples the relatively wide pulses produced by the cells and puts out very narrow uniform pulses of $2 \mu\text{sec}$ width with the same amplitude. These narrow pulses go to a Nuclear Data pulse height analyzer (model ND-110),¹⁶ which distributes the pulses into 128 channels. When an analysis is completed, the distribution of pulse amplitudes is stored on magnetic tape. The distributions can be plotted using various normalizing procedures. The count rate, the output of the main amplifier, and the pulse height analyzer memory are monitored as shown in Fig. 1.

The instrument has been evaluated mainly with human red blood cells (erythrocytes) from blood samples obtained from the Stanford Hospital Clinical Laboratories. Thus clinical and other laboratory data are available on these blood samples, including the mean cell volume (MCV) determined by the Coulter counter model S.¹ The blood is collected in Vacutainer B-D¹⁷ tubes with an approximate draw of 7 ml and an additive of 7 mg EDTA (disodium ethylenediaminetetraacetate) to prevent coagulation. Five microliters of this blood are diluted in 20 ml of Tris buffered saline ($0.01M$ Tris,¹⁸ $p_H=7.5$, in $0.15M$ NaCl). The dilution is not critical because we are only interested in relative numbers. The count rate is adjusted by varying the reservoir head pressures to keep coincidence peaks to a negligible fraction. Our standard flow rate is approximately 2000 cells/sec. Blood taken from the technician who operates the machine is used as a standard to insure reproducibility of operation. The assumption that the MCV of the technician's blood will remain essentially constant from day to day under normal conditions is supported by the data of Brittin *et al.*¹⁹

The relationship of the pulse height to the volume of the cell being measured has been treated in many papers. Many authors²⁰⁻²⁵ have worked with various derivations and, although some of the approximations made in these calculations are somewhat questionable, they all come to essentially the same result for rigid spheres,

$$(\rho' - \rho_2) / \rho_2 = 1.5\delta, \quad (1)$$

where ρ_2 is the resistivity of the orifice containing no particle, δ is the ratio of the volume of the cell particle to the volume of the orifice, and ρ' is the resistivity of the

orifice containing a particle. The major assumptions involved in this result are that $\delta \ll 1$ and that $\rho_2 \ll \rho_1$ where ρ_1 is the resistivity of the particle. Gregg and Steidley²⁴ have conducted model measurements which support the above equation reasonably well, and they also furnish data indicating that ρ_1/ρ_2 is on the order of 10^4 . For erythrocytes in our orifice, the value of δ is around 10^{-4} .

Unfortunately, erythrocytes are not rigid spheres, but biconcave disks. Electrical current flow lines will not follow flat (much less concave) surfaces that are normal to the flow of current. This means that if a disk is flowing with its axis of symmetry parallel to the axis of the orifice, it will give a signal that is of the order of $1\frac{1}{2}$,¹⁴ 2^4 ,²² or 3 ,²⁴ times larger than that of an equivalent volume sphere. If the disk flows edge-on through the orifice, the signal is equal to,²² or 0.8 of,⁴ that of a sphere of equal volume. Gregg and Steidley²⁴ state that experimental evidence indicates that for erythrocytes the equation should be

$$(\rho' - \rho_2)/\rho_2 = \delta, \quad (2)$$

because of the disk's rounded edges.

We decided to do the day-to-day calibration of our instrument using the nominal MCV's of a few normal blood samples, as determined by the Coulter counter model S.¹ By plotting the mean signal from our machine against the MCV from the Coulter counter for the same blood samples and drawing a straight line through the points, we can calibrate our output. The Coulter counter model S has been shown to be repeatable in its measurements,¹⁹ and, lacking any other standard, we have fallen back on it to give us calibration without resorting to the somewhat uncertain calculations.

If the cells had a random orientation as they traversed the orifice, one would expect a very broad volume distribution. Bull¹⁴ has reported changes in the shape of the volume distributions when there are disturbances of the flow pattern around the orifice (turbulence). Possible causes for this effect could be tumbling of the cells in the orifice or interactions with inhomogeneities of the electric field in the orifice. An analysis of the hydrodynamic field in the Coulter orifice was made by Grover *et al.*²³ They show that the core region of quiescent irrotational flow has a radius greater than half the orifice radius from the orifice mouth to approximately four orifice radii downstream. The inner stream in our machine has a radius less than $\frac{1}{4}$ the orifice radius, and the orifice length is only $3\frac{1}{3}$ orifice radii so the cells remain in the core during the orifice passage. Since the core is irrotational and since the cells are in the orifice for only about $10 \mu\text{sec}$, they should pass through the orifice oriented the way they entered it. Since our volume distributions for normal blood (Figs. 3 and 4) are not wide, the cells may go through the orifice in a preferred orientation. If some shear is assumed at the tip of the glass nozzle which injects the

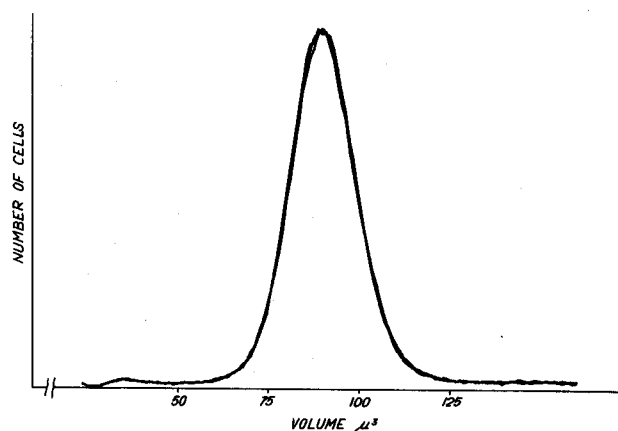

FIG. 3. Three consecutive analyses of the same dilution of normal blood to show the precision of the instrument.

central stream, the erythrocytes might orient edge-on and thus be measured that way. Another explanation advanced by Thom *et al.*⁴ suggests that unfixed cells are distorted by hydrodynamic forces at the orifice to a generally uniform shape, regardless of orientation. The sharpness of our distributions indicates a mechanism something like these occurs.

RESULTS AND DISCUSSION

Figure 3 shows three consecutive analyses of the same blood dilution (typical outputs for normal human peripheral blood). The short term precision of our instrument is excellent; the three distributions plotted together could be mistaken for a single distribution. The small peak at the very small volume end of the graph is due to system electrical noise. For normal blood, the shape of the distribution is reasonably symmetrical with a small tail (a few percent) of larger signals. A variability of the width of blood distributions for normal patients was observed.

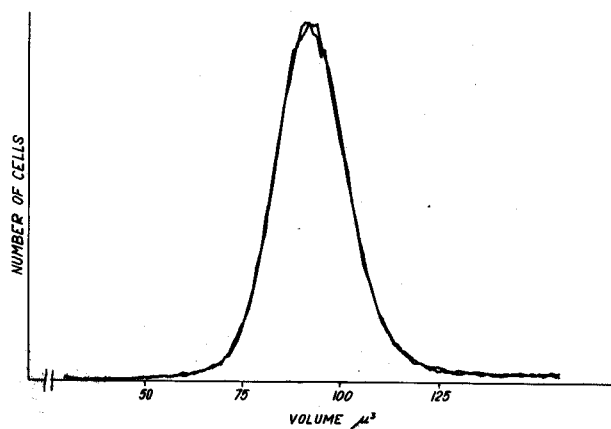

FIG. 4. Two volume distributions of the same normal blood. The two analyses were separated by 1 h 45 min, during which time several other blood samples were analyzed.

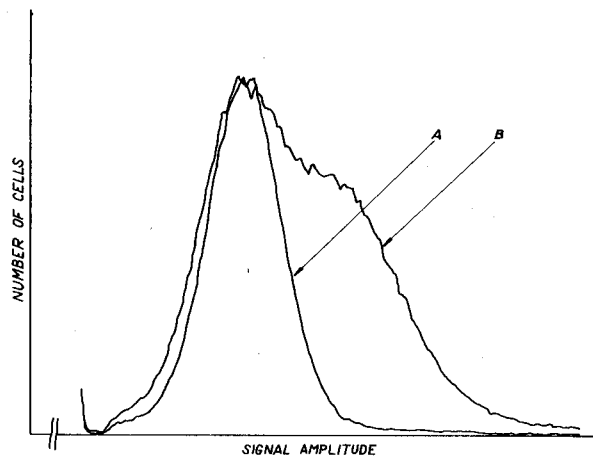

FIG. 5. Two volume distributions from different patients. Distribution A is from a normal patient; distribution B is from a patient with reticulocytosis (large numbers of immature erythrocytes).

Present data are insufficient to state whether this was due to differing periods of storage at room temperature or due to actual biological differences. Figure 4 shows two analyses of normal blood made 1 h and 45 min apart, during which time five other blood samples were each analyzed three times. This figure shows the longer term precision obtainable on this instrument. Figures 3, 4, 6, and 9 are the actual output of our system. Figures 5, 7, 8, and 11 are traced from the outputs so that the individual distributions can be told apart.

In contrast to the symmetrical nature of normal blood distributions, Fig. 5 shows the volume distribution of blood from a patient with reticulocytosis (a disease characterized by an abnormally large population of immature erythrocytes which seem to be larger than mature cells) and of blood from a normal patient. Normal incidence of

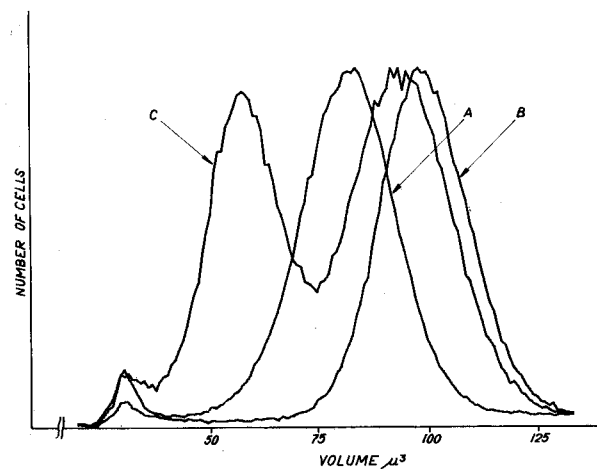

FIG. 6. Three volume distributions from different patients. Distributions A and B are from patients who are, respectively, somewhat microcytic and somewhat macrocytic. Distribution C is from a patient who had had a massive transfusion, and the two populations are clearly evident.

reticulocytes is about 0.8%, but patient B had 26% of his blood cells as reticulocytes. As can be seen, distribution B has a strong departure from normality, with a pronounced shoulder of larger cells. The shoulder appears to contain more than 26% of the cells.

The volume distributions of three different patients are shown in Fig. 6. The nominal MCV's of patients A, B, and C, as given by the Coulter counter model S, are, respectively, 75, 101, and 77 μ^3 . It is obvious that there are two cell populations in distribution C. Investigation disclosed that the patient had received a massive transfusion, and we were seeing the two populations which were averaged together by the Coulter counter. Patients A and B are included to show the range of volumes usually seen. Their respective MCV's lie just outside the outer bounds of the normal range. Thus a large range of cellular volumes are easily measured, and the gain can be varied to look at even smaller or larger cells.

In order to investigate the theoretical effect of several variables on the pulse amplitudes, some manipulation of the preceding equations is needed. Equation (2) shows that

$$\Delta\rho/\rho_2 = \delta.$$

Multiplying top and bottom of the left side of the equation by L/A , where L is the length, and A the cross sectional area of the orifice, and, rearranging, we get the resistance

$$\begin{aligned} \Delta R/R &= [L(\Delta\rho)/A]/(L\rho_2/A) = \delta, \\ \Delta R &= L\rho_2\delta/A = L\rho_2\delta/\pi r^2. \end{aligned}$$

If v is the volume of the cell and r is the radius of the orifice, then $\delta = v/\pi r^2 L$, and

$$\Delta R = \rho_2 v / \pi^2 r^4.$$

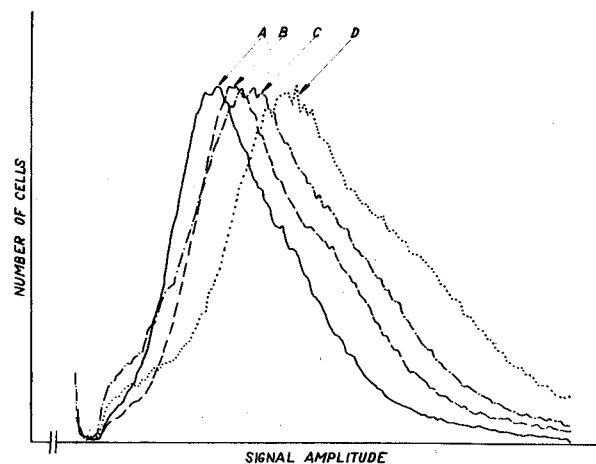

FIG. 7. Four distributions from the same reticulocytosis patient, but analyzed with different media in the inner stream: A—Isoton; B—9 parts saline, 1 part Isoton; C—PBS; D—saline.

Using Ohm's law for a current source

$$\Delta V = I(\Delta R),$$

the signal

$$\Delta V = I\rho_2 v / \pi^2 r^4. \quad (3)$$

Although the use of smaller orifices could greatly increase signal strength, the variation of signal amplitude caused by even a slight deposition of debris on the orifice is relatively much greater in smaller orifices. As can be seen from the simplified development above, the variation in signal for a given cell is inversely proportional to the fifth power of the radius of the orifice [$\partial(\text{signal})/\partial r \propto 1/r^5$]. The orifice must be kept clean for reproducible operation. In addition, clogging becomes more of a problem with very small orifices. The buffer solution is prefiltered through a 0.45μ Millipore²⁶ filter, and the cell suspension passes through a 400-mesh stainless steel filter again on its way to the head. The pressurizing air is not filtered. Normal hydrochloric acid is run through the system every day both to remove clinging cell debris and oxides and to get rid of the ferric hydroxide precipitate which forms from the electrolysis of the stainless steel tubing used to make electrical contact with the solution. It has been found necessary to remove the orifice assemblies and clean them in an ultrasonic cleaner once or twice a day since the acid is not sufficient. If the curve of the standard blood drifts, the orifice assemblies are cleaned with ultrasound. Following these procedures the drift can be held to a few percent (see Fig. 4).

Bubbles cause problems in this system. Passing an electric current through a saline solution produces bubbles of hydrogen and chlorine at the electrodes. The tiny bubbles of chlorine passing through the orifice cause spurious signals, but the number is much smaller than the cell count. Large bubbles must be removed from the upper chamber to achieve good signals. Large bubbles in the

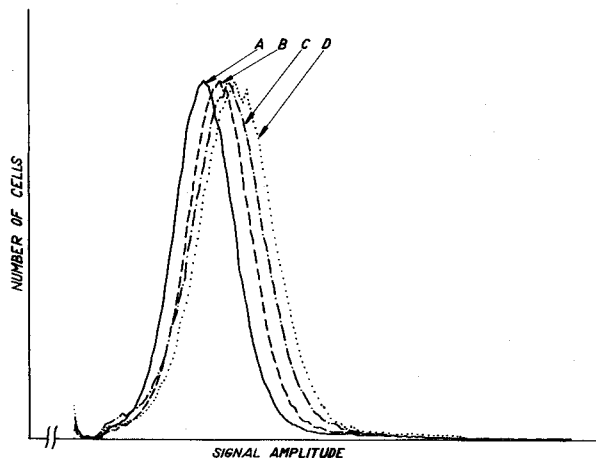

FIG. 8. Four distributions from the same normal patient, but analyzed with different media in the inner stream: A—Isoton; B—9 parts saline, 1 part Isoton; C—PBS; D—saline.

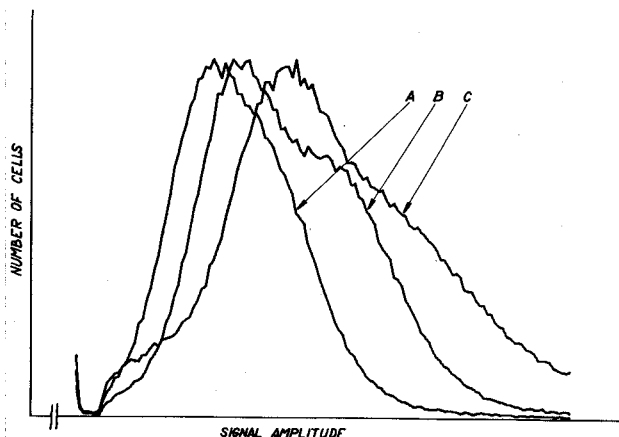

FIG. 9. Three distributions from a reticulocytosis patient analyzed with different media in the inner stream: A—Isoton, one day after the blood was drawn; B—saline, one day after being drawn; C—saline, five days after being drawn. Compare A and B for media difference, and B and C for storage time difference.

lower chamber can be tolerated as long as they do not cover the electrode or encroach too closely on the orifices. A bubble sitting on the jewel completely interferes with the signals and must be flushed away for the analysis to continue.

The system is quite sensitive to the composition of the suspending medium. Figures 7 and 8, respectively, show red blood cell volume distributions from a patient with reticulocytosis and from a normal patient, analyzed with four different media in the inner and Isoton (Coulter Diagnostics, Incorporated)¹ in the outer stream. On both figures, the far left distribution was analyzed with Isoton in the center stream; the next distribution was analyzed with a 1:9 (v/v) mixture of Isoton and 0.9% sodium chloride (saline); the third distribution was analyzed with 0.9% sodium chloride, 0.01M phosphate, p_H 7.0 (PBS); and that on the right was analyzed using saline. The conductivity of Isoton is greater than that of saline, suggesting it is hypertonic. This would explain some of the differences shown in the figures, since a hypertonic solution would cause the cells to shrink somewhat and would give smaller signals for this reason and also because of the lower resistivity of the medium itself [see Eq. (3)]. More data on the effect of different buffers on the output of our system can be seen in Fig. 9. The blood is from the same reticulocyte patient shown before. The abnormal blood samples seem to be more affected by the different treatments than the normal samples. The large volume shoulder is much more evident in distribution B, analyzed in saline, than in distribution A, analyzed in Isoton.

Figure 9 also shows that the distribution of the blood analyzed five days after being drawn (C) has a greater variance than that analyzed only one day after being drawn (B), even though the blood was stored on ice or in the refrigerator. The blood samples from the clinical labora-

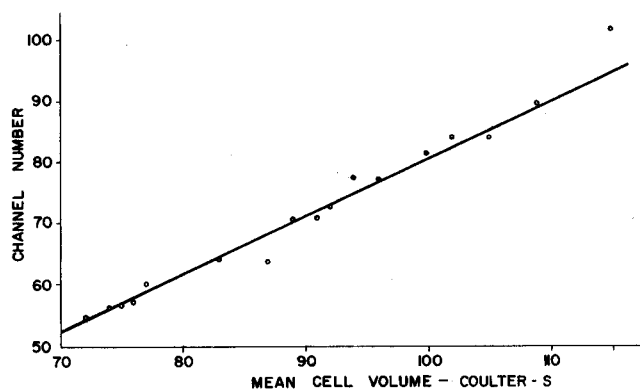

FIG. 10. A graph of the channel number corresponding to the mean signal measured from our data vs the MCV as determined by the Coulter S.

tories were left at room temperature for several hours before being refrigerated. Following such treatment the distributions (even of normal blood) often exhibit a greater variance after a few days. The standard blood, which is kept cold from the minute it is drawn, maintains its original distribution more closely. This finding is substantiated by the study of Brittin *et al.*²⁷ They showed that storage for 24 h at room temperature causes the MCV of EDTA treated blood to increase by about 3%, while storage for 24 h in the refrigerator causes no change in the MCV.

Our choice of 0.01M Tris¹⁸ buffered saline avoided a possible effect of high phosphate concentration on the cells (Isoton appears to be a phosphate buffered solution). Stock solution of Tris (0.1734M Tris is isotonic at $p_H=7.5$) is diluted to 0.01M Tris with saline. All stock solutions are routinely stored in the refrigerator to minimize evaporation losses and to inhibit bacterial growth.

Figure 10 is a study of the linearity of the mean signal from the impedance analyzer vs the MCV indicated by the Coulter counter model S. Equation (3) predicts a linear relationship between signal amplitude and cell volume for a given orifice and suspending medium. The figure shows that, within the range of volumes in which we are interested, the output of our instrument is reasonably linearly related to the volume of the cells.

The standard Coulter orifice produces volume distributions for normal erythrocytes which have substantial positive skewness. A possible cause for this skewness could be inhomogeneities in the electric field near the boundaries of the orifice.¹⁴ Grover *et al.*²⁸ published a very elegant derivation for the electric field inside the orifice and showed that the orifice should be longer than it is wide to obtain a uniform field in at least part of the orifice. They also show that in an annulus between $0.8r$ and r (where r is the radius of the cylindrical orifice), the electric field is higher at the two ends of the orifice than the uniform field in the center of the orifice. Model mea-

surements conducted by Thom *et al.*⁴, using an electrolytic tank, substantiate this derivation very clearly. A pulse produced by a cell traveling close to the wall of the orifice is saddle shaped due to the higher fields at the entrance and exit of the orifice, thus tending to cause positive skewness of the distribution. The model studies indicate that the annulus containing the higher fringing fields is between $0.6r$ and r , which agrees closely with the calculations.

If the outer flow is turned off in our system, leaving just the inner flow running, it approximates the conditions in the Coulter orifice, and the curves obtained are considerably skewed from the normal nearly symmetrical distributions obtained from the coaxial sheath flow mode. These differences are shown in Fig. 11 where distribution A represents a normal blood sample analyzed under normal sheath flow conditions, distribution B represents the same blood analyzed without the outer flow (at 0.1 the concentration of cells to provide equivalent cell flow rates), and distribution C represents the same blood analyzed in the Coulter counter model B¹ at the appropriate concentration to give the same cell flow rate. The signals from the Coulter counter were fed into the peak follower and the pulser height analyzer to obtain the distribution. The blood samples were washed twice with Tris buffered saline to remove the plasma and resuspended in Tris buffered saline at the appropriate concentrations to be analyzed. The distributions in this figure were normalized such that there are equal areas beneath each curve. Thus the height of the main peak is a function of the sharpness of the distribution. In distributions B and C, the cells are not constrained to the center of the orifice. Since almost $\frac{3}{4}$ of the orifice cross section has higher fringing fields near the exit and entrance, most cells will be given artificially large pulse amplitudes due to these fields. Thus one would expect a general shift to the right, together with a large tail of larger signals, caused by those cells very near the

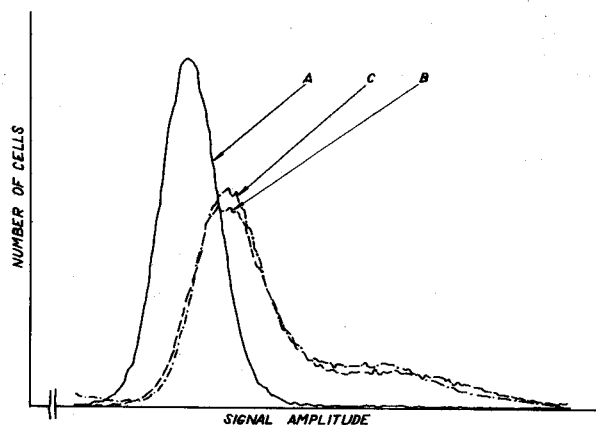

FIG. 11. Three distributions of the same normal blood analyzed in three different ways: A—coaxial flow, in our instrument; B—no outer flow, in our instrument; and C—in Coulter counter model B. The three graphs are normalized with respect to area under the curves.

walls of the orifice, and perhaps random orientations of the cells themselves. In distribution A the cells are constrained to within about $0.2r$ of the orifice axis, and the large tail is almost completely absent. Since distributions B and C come from different instruments, the amplifier gain distribution C was adjusted to bring the main peaks to the same abscissa position for comparison.²⁸

Since the impedance analyzer confines the cells to the center of the orifice where the electric field is much more uniform and where there is less turbulence, it should be able to detect small anomalous populations of cells in a blood sample. The skewness of the standard Coulter orifice is quite constant¹⁹ and gives a repeatable nominal MCV. However, its resolution is hampered by the problems mentioned above. Our instrument is relatively simple to construct; the only precise workmanship required is in the construction of the head (Fig. 2). It is also relatively easy to operate, requiring little technical knowledge and should find widespread use in the clinical laboratory.

* Work supported in part by the National Institute of Health Grants No. GM-17367, CA-04681, and 5-TOI GM-295-12, and in part by NASA Grant No. NGR-05-020-004.

† Department of Genetics.

‡ Department of Pathology.

¹ Coulter Electronics, Inc., 590 West 20th Street, Hialeah, Fla. 33010.

² P. J. Crosland-Taylor, *Nature* **171**, 37 (1953).

³ P. F. Mullaney, M. A. Van Dilla, J. R. Coulter, and P. N. Dean, *Rev. Sci. Instrum.* **40**, 1029 (1969).

⁴ R. Thom, A. Hampe, and G. Sauerbrey, *Z. Ges. Exp. Med.* **151**, 331 (1969).

⁵ R. C. Leif, in *Automated Cell Identification and Cell Sorting*, edited by G. L. Wied and G. F. Bahr (Academic, New York, 1970), p. 131.

⁶ C. C. Lushbaugh, J. A. Maddy, and N. J. Basmann, U. S. At. Energy Comm. Rep. LAMS-2526, 372 (1960).

⁷ C. C. Lushbaugh, J. A. Maddy, and N. J. Basmann, *Blood* **20**, 233 (1962).

⁸ C. C. Lushbaugh and D. B. Hale, U. S. At. Energy Comm. Rep. LAMS-3034, 270 (1962-1963).

⁹ C. C. Lushbaugh and D. B. Lushbaugh, *Southern Med. J.* **58**, 1208 (1965).

¹⁰ H. E. Kubitschek, *Rev. Sci. Instrum.* **33**, 576 (1962).

¹¹ M. A. Van Dilla, N. J. Basmann, and M. J. Fulwyler, U. S. At. Energy Comm. Rep. LAMS-3132, 182 (1964).

¹² M. A. Van Dilla, N. J. Basmann, and M. J. Fulwyler, U. S. At. Energy Comm. Rep. LAMS-3132, 190 (1964).

¹³ M. A. Van Dilla, N. J. Basmann, and M. J. Fulwyler, U. S. At. Energy Comm. Rep. LAMS-3132, 197 (1964).

¹⁴ B. S. Bull, *Blood* **31**, 503 (1968).

¹⁵ G. F. Bahr and E. Zeitler, *Lab. Invest.* **11**, 912 (1962).

¹⁶ Nuclear Data, Inc., P. O. Box 451, Palatine, Ill. 60067.

¹⁷ Becton, Dickinson, and Company, Columbus, Nebraska-Rutherford, N. J.

¹⁸ Tris (hydroxymethyl) aminomethane, "Sigma 7-9," SIGMA Chemical Company, 3500 De Kalb St., St. Louis, Mo. 63118.

¹⁹ G. M. Brittin, M. D., G. Brecher, M. D., and C. A. Johnson, B. S., MT (ASCP), *Amer. J. Clin. Path.* **52**, 679 (1969).

²⁰ J. C. Maxwell, *A Treatise on Electricity and Magnetism* (Dover, New York, 1954), 3rd ed., Vol. 1, p. 437.

²¹ H. E. Kubitschek, *Research (London)* **13**, 128 (1960).

²² M. J. Fulwyler, Ph.D. thesis, University of Colorado, Boulder, Colorado, 1969.

²³ N. B. Grover, J. Naaman, S. Ben-Sasson, and F. Doljanski, *Biophys. J.* **9**, 1398 (1969).

²⁴ E. C. Gregg and K. D. Steidley, *Biophys. J.* **5**, 393 (1965).

²⁵ J. Hurley, *Biophys. J.* **10**, 74 (1970).

²⁶ Millipore Filter Corp., Bedford, Mass.

²⁷ G. M. Brittin, M.D., G. Brecher, M.D., C. A. Johnson, B. S., MT (ASCP), and R. M. Elashoff, Ph.D., *Amer. J. Clin. Path.* **52**, 690 (1969).

²⁸ One referee has pointed out that, in his opinion, the experimental results described here conflict with the theoretical calculations of Grover *et al.*²³ on average pulse amplitude increase and also with some similar work done by Thom *et al.*⁴